

BUZZBOMB

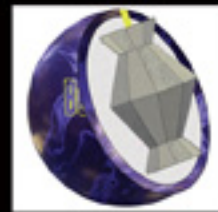

Drilling Specifications

Pin Position

The BuzzBOMB's 12:00 pin, in relation to the CG, makes this ball driller friendly for right & leftand bowlers.

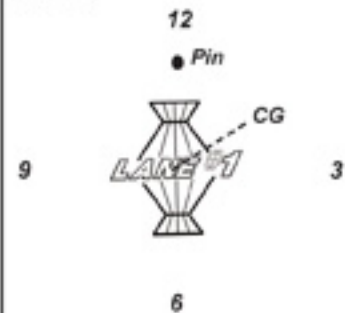

Turning the pin towards 3 O'clock, relative to the CG, will increase length.

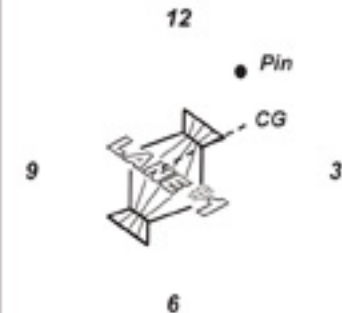

Turning the pin towards 9 O'clock, relative to the CG, will decrease length.

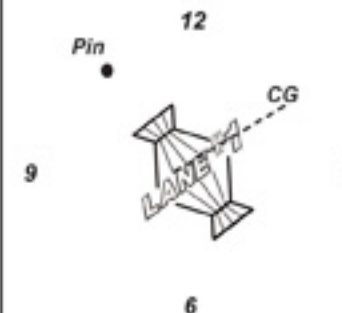

Pin and CG distance from axis

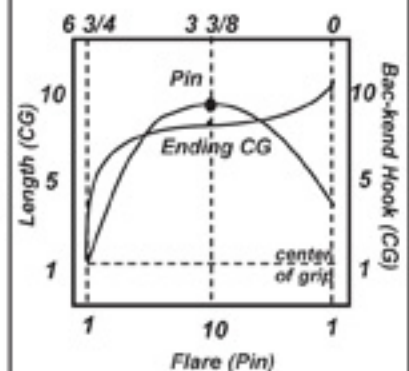

Drilling Recommendations

Label

For higher tracks & shorter pins

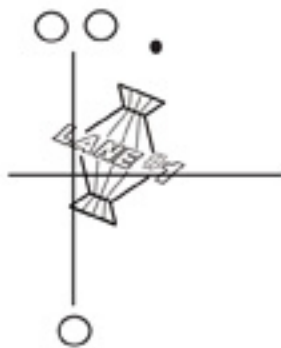

Flare 8 Back-end 9

Pro Pin High RG

Control for High Revs

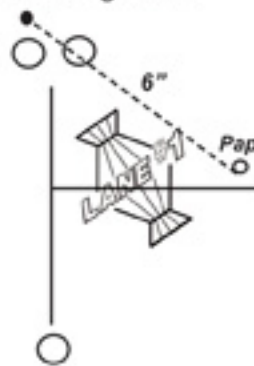

Flare 2 Back-end 5

Stacked

For Medium to Lower Revs

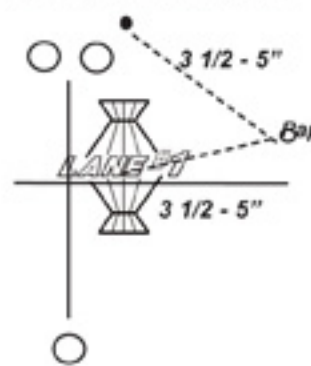

Flare 9 Back-end 8

CG Out Leverage

Power with Control on THS

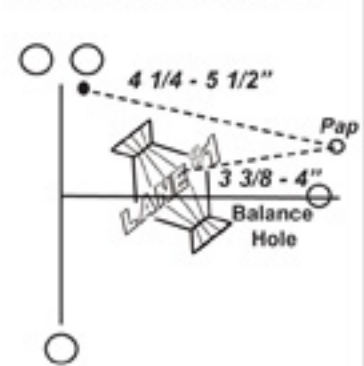

Flare 7 Back-end 7

Pin in Palm (Rico)

For lower tracks

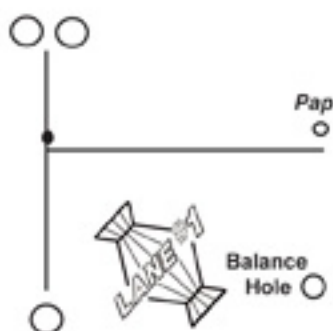

Flare 6 Back-end 6

Axis Leverage

Hole on Axis For Wet/Dry

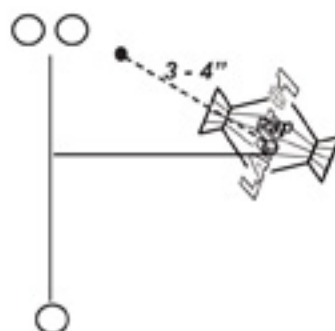

Flare 8 Back-end 6

Full roller

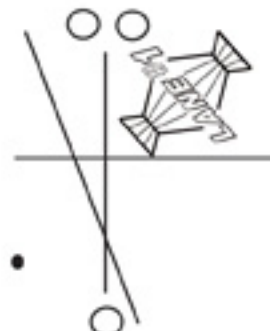

Flare 8 Back-end 8

Notes

1. Pos. side, finger, & top wt., increase length and back-end.
2. Neg. side, thumb, & bottom, decrease length and back-end.
3. Axis holes decrease flare and back-end reaction.
4. Pin-in balls and pin below fingers decrease length and flip.
5. Pin-out balls and pin above fingers increase length and flip.
6. If the ending center of gravity is on your pin, starting CG, or on the same rotational plane as those, ball reaction is enhanced.